

MAINTENANCE OF TYPE 230 & 230-PM CONTROLLERS

SCOPE This bulletin outlines our general recommendations on inspection, adjustments, safety precautions, check-out, and vacuum integrity test for the Type 230 and 230-PM Controllers. The bulletin also includes Contactor Operating Dimensions measured during inspection. These controllers are for control of 2300-4160-volt motors or transformers. See Bulletin 230 or 230-PM for controller description and Bulletin 1032 for Renewal Parts List.

INSPECTION At regular intervals, depending upon frequency of operation and other application conditions, open the controller and make a complete inspection of contactor, the contactor switching elements (see Sketches), isolating switch contacts, fuse clips, high voltage insulation, and other parts. When necessary, clean all insulation, tighten fasteners, and replace damaged or worn parts.

ADJUSTMENTS Field adjustments are not normally required or recommended. The contact travel and position of the contacts in the main contactor, are factory set and adjustments are not recommended except when replacing the vacuum switches. The Overload Relay is factory set at 100% of rating. This may be adjusted over a range of 85%-115% by turning an adjustment knob on the bottom of the relay. Check with us or see Bulletins 9-31660 and 9-32730 for recommended changes in fuse size, current transformers, and overload relay heaters, in case of changed HP or KVA application.

SAFETY PRECAUTIONS The controller is equipped with an isolating switch, safety-interlocked to prevent its accidental operation under load. Mechanical interlocks also prevent opening the door before opening the isolating switch or closing the isolating switch with the door open. Open or close the isolating switch only when the control power switch on the front of controller is in the "Stop" position, and the main contactor is open. Don't try to open the door before opening the isolating switch. Don't close the isolating switch with the door open. When working in the controller or on the circuit, consider padlocking open the isolating switch. Also consider grounding load terminals.

CHECK-OUT Inspection of the vacuum switching elements of the contactor requires electric operation of the contactor. Before checking-out controllers or remote-control connections, refer to wiring diagram. When you use a temporary, separate 115-volt source for control power, take care to avoid back feeding the control power transformer. Disconnect connections to the secondary side of the control power transformer and remove the intentional ground from the normal control circuit. As a safety precaution, consider grounding and shorting both the primary voltage side of control transformer (fuses removed) and its secondary terminals.

VACUUM INTEGRITY TEST In order to verify vacuum integrity of the contactor vacuum interrupters, periodically use a 12KV RMS 60HZ dielectric withstand test across the open contacts.

CONTACTOR OPERATING DIMENSIONS

Contact condition and mechanism wear are indicated through two measurements on the three switching assemblies:

1. **OVERTRAVEL** With the contactor in the "closed" or "on" position, the spherical washers should be loose under the actuating stud of each switching assembly as shown in Sketch #1.
2. **MOVING CONTACT TRAVEL** When switching the contactor between the "open" and "closed" positions, check the moving contact travel on each switching assembly as shown in Sketch #2.

Sketch #1

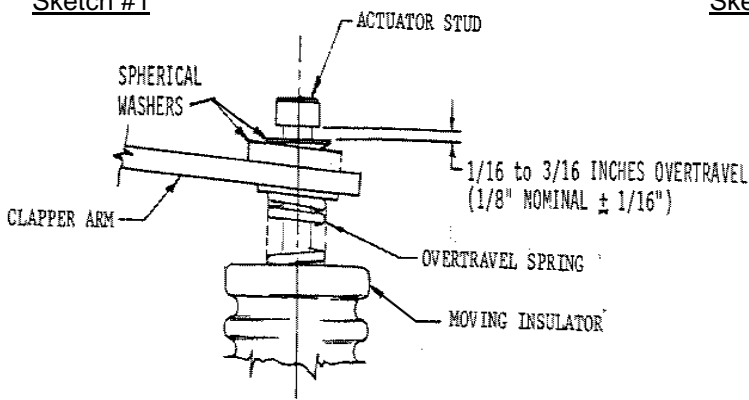

Sketch #2

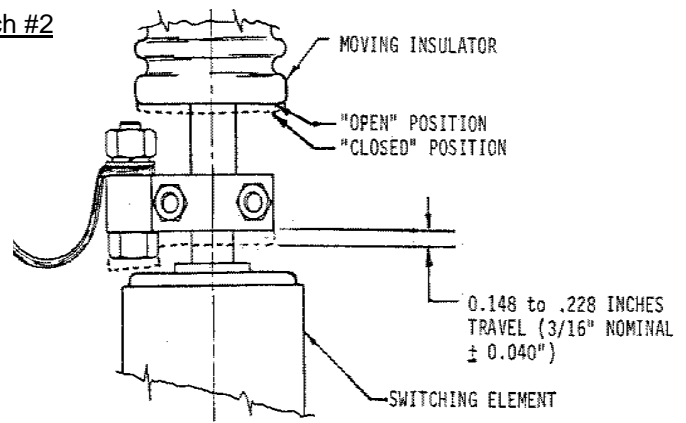

If either of the measurements above is found to be outside of the specified dimensions, vacuum bottle damage or excessive contactor mechanism wear is indicated.